

Repair and Parts Manual



This document contains confidential, proprietary trade secret information which is the property of Ancra International (the "Company") and receipt or possession does not convey any license or rights to use, loan, sell, reproduce or otherwise disclose said information, except as expressly agreed in a writing signed by the Company. This document, and all copies thereof, are to be returned to the Company upon request and in all events upon

This is an unpublished work. The disclosure of this work is limited to select personnel. Further dissemination or disclosure to the public is PROHIBITED. This unpublished work is protected by U.S. Copyright law and corresponding foreign copyright laws, and all rights thereunder are reserved by Ancra International.

Repair and Parts Manual

Table of Contents

System Inspection - General	3
LAD II Beams	4
49414-14 & -15 Standard Duty Beams Parts Illustration	6
49414-19, -24 & -25 Heavy Duty Beams Parts Illustration	7
50080-11 Wide Flanged Beam Parts Illustration	8
50312-10 Reinforced Wide Flanged Beam Parts Illustration	9
LAD II High Raise Beams	10
49414-17 Standard Duty High Raise Beams Parts Illustration	11
49414-23 Heavy Duty High Raise Beams Parts Illustration	12
LAD II Beam Foot Sub-Assemblies and Replacement Parts Illustration	13
LAD II Beam Assembly Inspections	14
Beam Assembly Replacement Criteria	14
Foot Replacement Criteria	14
Beam Assembly Removal	15
Beam Assembly Installation	15
Beam Extrusion Replacement	15
Beam Foot Assembly Replacement	16
Beam Foot Replacement	16
LAD II Track	17
LAD II Track Inspections	18
Track Replacement Criteria	18
Track Removal	19
Recommended Track Attachment Fasteners	19
Sheet & Post Type Trailer Wall Construction	19
Plate Type Trailer Wall Construction	19
Replacement Track Installation	19
LAD II Beam Stop	20
Beam Stop Installation	20
LAD II Door Track Guard (For Roll-Up Door Trailers Only)	21
Door Track Guard Removal	21
Door Track Guard Installation	21
LAD II Adjustment Tool	22
Adjustment Tool Repair – Loose Rivets	22
LAD II Adjustment Tool Holder and Wall Placard	23
Adjustment Tool Holder Replacement	23
Wall Placard Replacement	23
Repair of Loose or Missing Track Attachment Rivets	24
Logistic Strap Replacement Criteria	24
System Lubrication	24
Appendix A, Replacement Beams & Beam Parts Weights	25
Appendix B, Replacement Track & Parts Weights	26
Appendix C, Examples of Damaged Beams and Track	27
Typical Examples of Damaged Beams	27
Typical Examples of Damaged Track	31

Repair and Parts Manual

System Inspection - General

Regularly inspect beams and beam components (including foot and foot assemblies), and track and track components, including beam stops and, if applicable, doublers for damage and excessive wear. Replace and repair missing or damaged components as necessary to ensure proper function of the system.

During all inspection, repair and replacement procedures make sure to use the proper beam release tool. Only the 49445 release bar should be used during both the release to bring the bar down from the top of the trailer and also during the movement of the beam upward back to its storage position. Do not stand directly underneath the beam while it is being raised or lowered in the track.

This document provides details of inspection criteria and replacement procedures. If there is additional detail required or questions, please call Ancra Cargo Systems Engineering at 859-371-7272 ext. 212.

To order replacement parts contact Ancra Sales and Customer Service at 859-371-7272 ext. 203.

CAUTION: Always use care when raising and lowering beams. Use the release tool 49445 and do not stand directly underneath beams when they are being raised or lowered.

CAUTION: Do not raise the beam, apply a load to or use the beam, allow the beam to remain installed in a trailer, or stand underneath the beam without all beam, foot assembly and track components installed.

WARNING: DO NOT OPERATE LAD II SYSTEM UNTIL ALL BEAM STOPS ARE IN PLACE.

Repair and Parts Manual

LAD II Beams

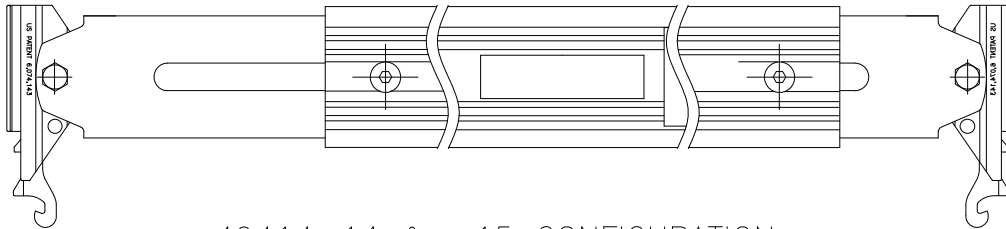

49414-14 & -15 CONFIGURATION

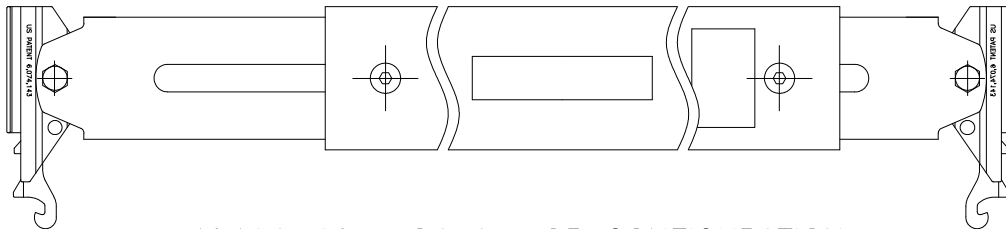
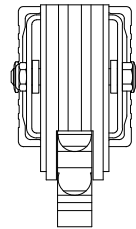

49414-19, -24 & -25 CONFIGURATION

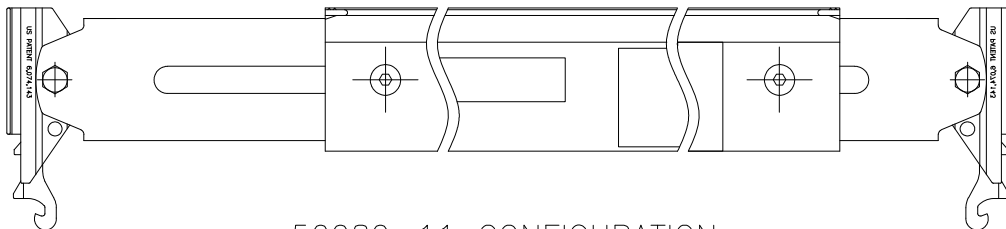
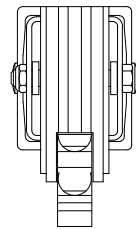

50080-11 CONFIGURATION

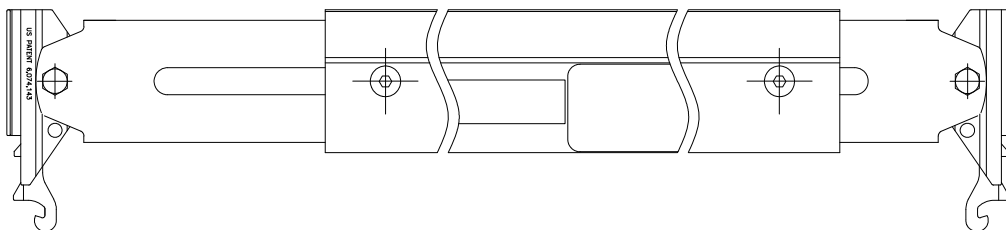
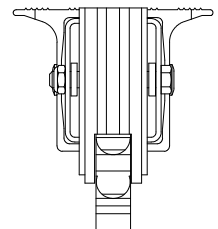

50312-10 CONFIGURATION

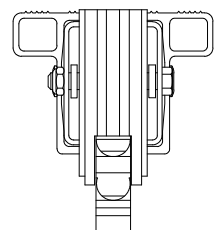

Repair and Parts Manual

LAD II Beams, cont.

49414-14	Standard Duty LAD II Beam Assy	87.9" - 98.4"	2,200lbs	2,200lbs
49414-15	Standard Duty LAD II Beam Assy	95.1" - 105.6"	2,200lbs	2,200lbs
49414-19	Heavy Duty LAD II Beam Assy	95.1" - 105.6"	2,500lbs	3,000lbs
49414-24	Heavy Duty LAD II Beam Assy	95.1" - 105.6"	2,500lbs	3,000lbs
49414-25	Heavy Duty LAD II Beam Assy	92.6" - 103.1"	2,500lbs	3,000lbs
50080-11	Wide Flanged LAD II Beam Assy	95.1" - 105.6"	Not Recommended	4,000lbs
50312-10	Reinforced Wide Flanged LAD II Beam Assy	95.1" - 105.6"	2,500lbs	4,000lbs

Repair and Parts Manual

49414-14 & -15 Standard Duty Beams Parts Illustration

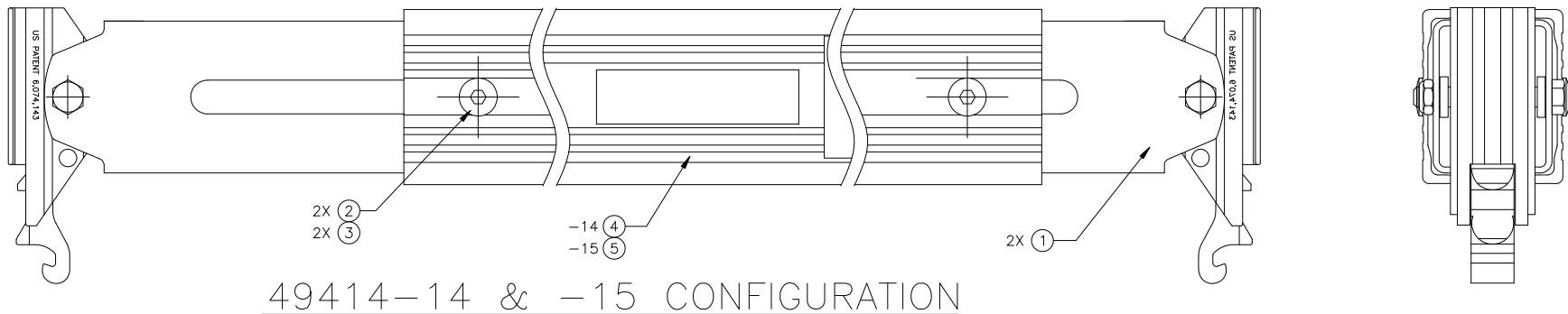

Item#	Part Number	Nomenclature	Quantity
1	49811-20L	Fitting Assembly	2ea
2	50194-10	Bolt, Low Profile	2ea
3	50194-11	Nut, Low Profile	2ea
4	49414-14-RT	Replacement Beam, Includes Decals	1ea
5	49414-15-RT	Replacement Beam, Includes Decals	1ea

Repair and Parts Manual

49414-19, -24 & -25 Heavy Duty Beams Parts Illustration

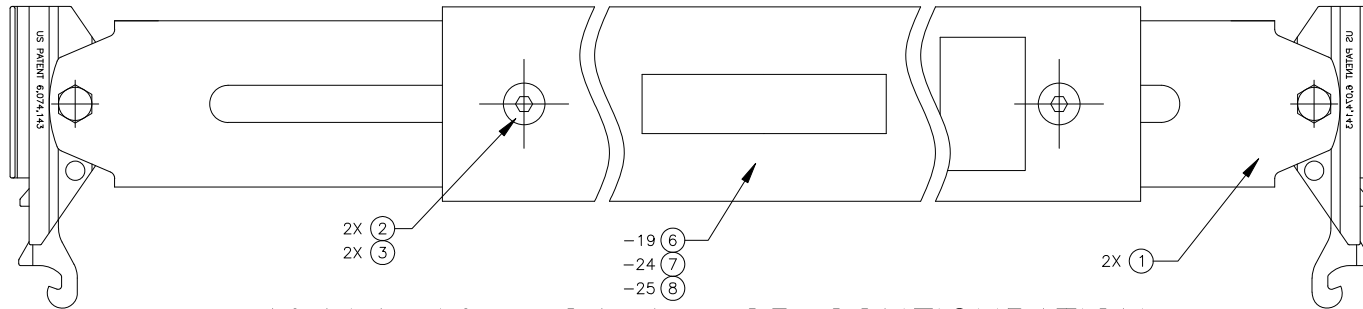

49414-19, -24 & -25 CONFIGURATION

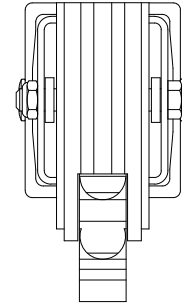

Item#	Part Number	Nomenclature	Quantity
1	49811-20L	Fitting Assembly	2ea
2	50194-10	Bolt, Low Profile	2ea
3	50194-11	Nut, Low Profile	2ea
4	49414-19-RT	Replacement Beam, Includes Decals	1ea
5	49414-24-RT	Replacement Beam, Includes Decals	1ea
6	49414-25-RT	Replacement Beam, Includes Decals	1ea

Repair and Parts Manual

50080-11 Wide Flanged Beam Parts Illustration

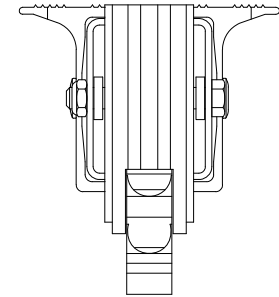
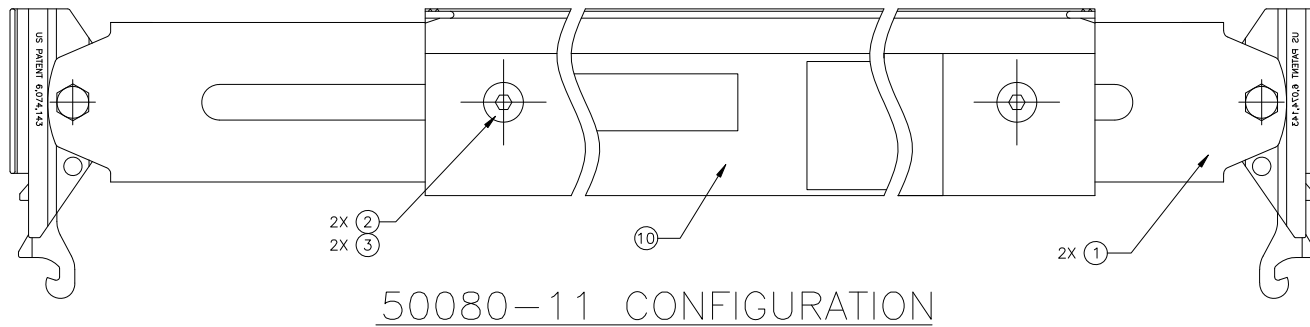

Item#	Part Number	Nomenclature	Quantity
1	49811-20L	Fitting Assembly	2ea
2	50194-10	Bolt, Low Profile	2ea
3	50194-11	Nut, Low Profile	2ea
4	50080-11-RT	Replacement Beam, Includes Decals	1ea

Repair and Parts Manual

50312-10 Reinforced Wide Flanged Beam Parts Illustration

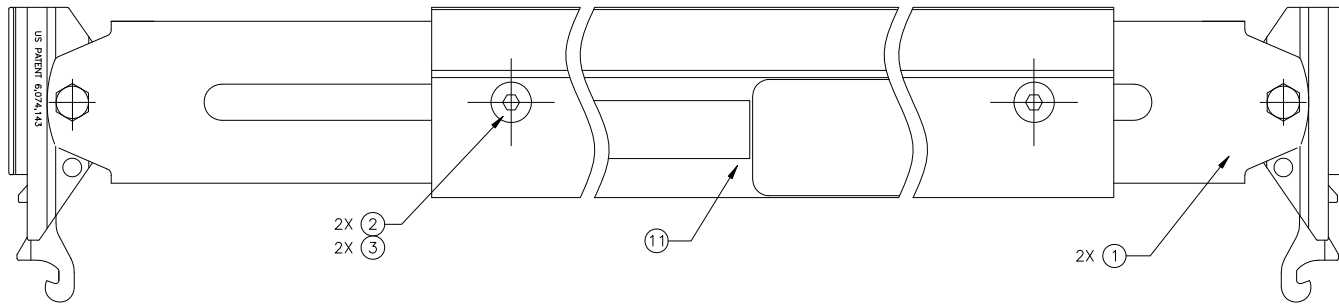

50312-10 CONFIGURATION

Item#	Part Number	Nomenclature	Quantity
1	49811-20L	Fitting Assembly	2ea
2	50194-10	Bolt, Low Profile	2ea
3	50194-11	Nut, Low Profile	2ea
4	50312-10-RT	Replacement Beam, Includes Decals	1ea

Repair and Parts Manual

LAD II High Raise Beams

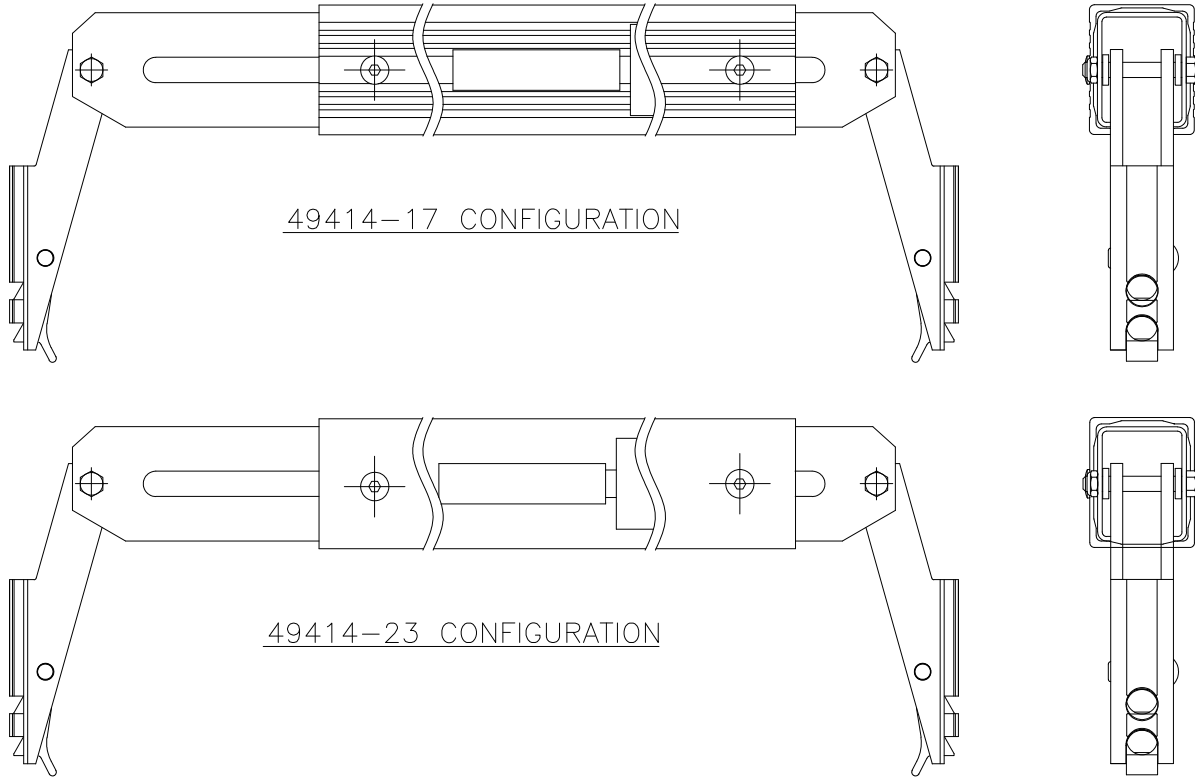

Part Number	Duty Type	Adjustment Range	Shoring WLL	Decking WLL
49414-17	Standard Duty LAD II High Riase Beam Assy	95.0" - 105.7"	1,450lbs	2,200lbs
49414-23	Heavy Duty LAD II High Raise Beam Assy	95.0" - 105.7"	1,450lbs	3,000lbs

Repair and Parts Manual

49414-17 Standard Duty High Raise Beams Parts Illustration

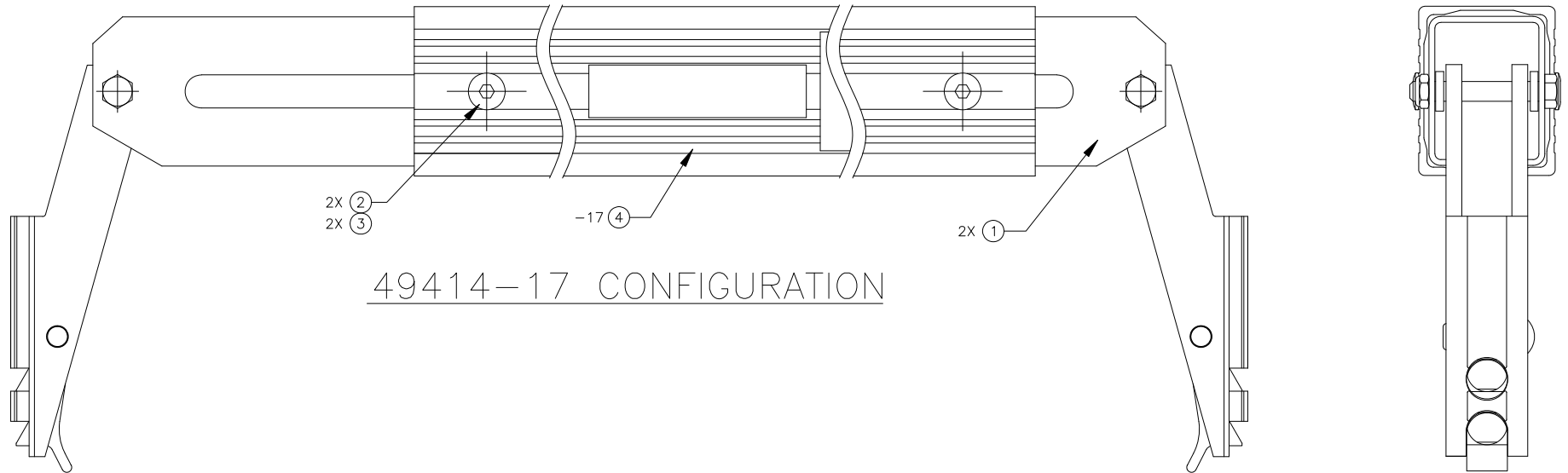

49414-17 CONFIGURATION

Item#	Part Number	Nomenclature	Quantity
1	49414-54	Fitting Subassembly	2ea
2	50194-10	Bolt, Low Profile	2ea
3	50194-11	Nut, Low Profile	2ea
4	49414-17-RT	Replacement Beam, Includes Decals	1ea

Repair and Parts Manual

49414-23 Heavy Duty High Raise Beams Parts Illustration

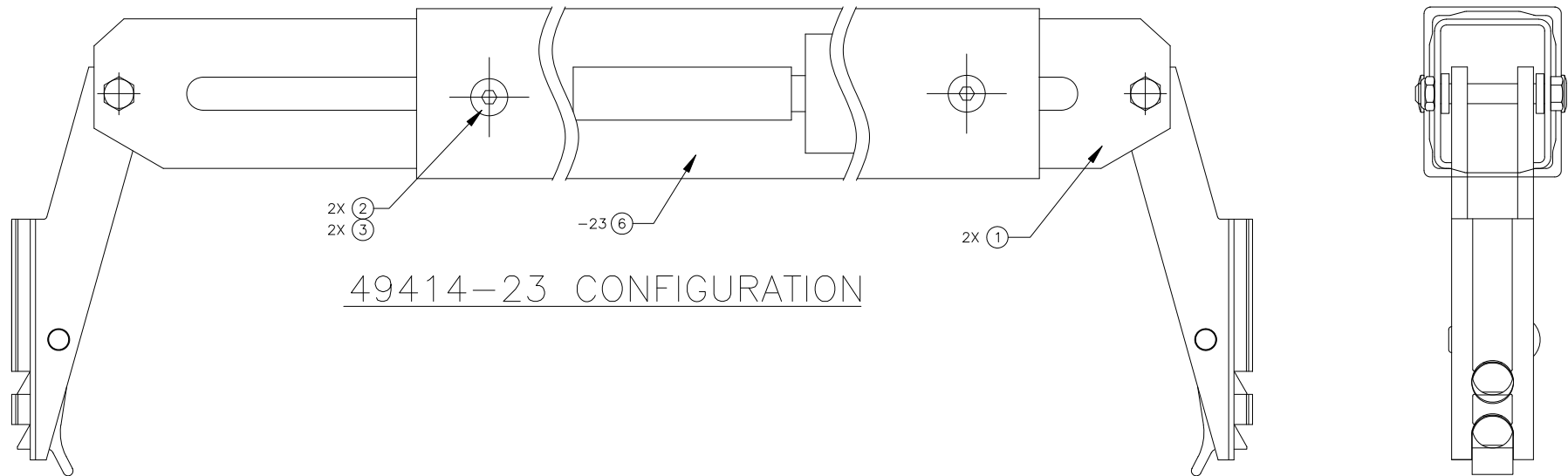

Item#	Part Number	Nomenclature	Quantity
1	49414-54	Fitting Subassembly	2ea
2	50194-10	Bolt, Low Profile	2ea
3	50194-11	Nut, Low Profile	2ea
4	49414-23-RT	Replacement Beam, Includes Decals	1ea

Repair and Parts Manual

LAD II Beam Foot Sub-Assemblies and Replacement Parts Illustration

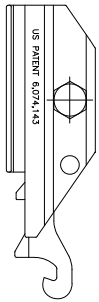

49811-21L
Beam Foot



49811-20L
Beam Foot Assembly



49414-54
High Raise Foot Assembly

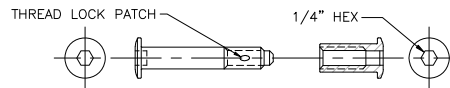

50194-100
Replacement Bolt Kit (1 each)

Repair and Parts Manual

LAD II Beam Assembly Inspections

Regularly inspect beams and beam components for damage and excessive wear. Replace or repair missing or damaged components as necessary to ensure proper functioning.

1. Check beam and foot assemblies for proper operation and damage.
2. Ensure all foot attachment hardware is secure.
3. Inspect foot assembly for damage.
4. Ensure trigger lock does spring back and engage track.

Beam Assembly Replacement Criteria

Beams must be replaced if any of the following conditions are found;

1. Deformations – bends, twists or curves in beams. (See Appendix B)
2. Holes or cracks
3. Any other damage where the system integrity is in question

NOTE: Beam Assemblies with beam extrusions that are bent or deformed (See Appendix B) but the Foot Assemblies are found to be functioning correctly may be repaired by replacing the beam extrusion.

Foot Replacement Criteria

Foot assembly must be replaced if any of the following conditions are found:

1. Wear in excess of 0.06" to the lock keys, illustrated below (also see Appendix B).
2. Broken or missing hardware.
3. Broken or weak lock spring. Minimum spring force should be 1.2lbs. to open locking trigger to clear track.

Note: Springs may be replaced per instructions in separate document #358.

4. Any other damage where the system integrity is in question.

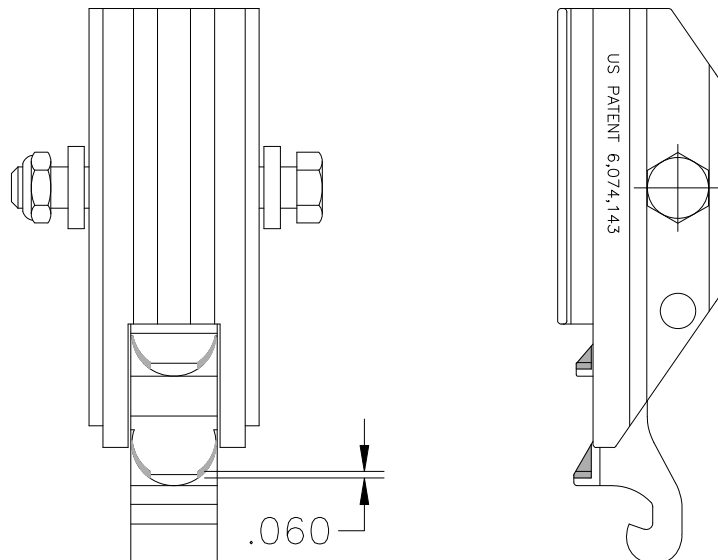

Repair and Parts Manual

Beam Assembly Removal

1. Remove beam stops from bottom of tracks at both ends of the beam and set aside for later reuse.
2. Using release tool, lift end of trigger lock away from wall to release trigger lock from track and lower beam as far as possible. Repeat for opposite end of beam.
3. Lower beam and slide both foot assemblies through the beam installation/removal slot (bottom end of track).

Beam Assembly Installation

1. Install beam, with reflective tape toward rear of trailer; slide foot assembly into the beam installation/removal slot (bottom end of track) at each side of the trailer.
2. Push up on beams until fully engaged in track holes. Beams should ratchet when pushed upward. Push beams up to top “storage holes” in track.
3. Reinstall beam stops per ***Beam Stop Installation*** instructions on page 20.

Beam Extrusion Replacement

1. Remove beam stops and beam per ***Beam Assembly Removal*** instructions above and place beam on secure work platform.
2. Remove foot attachment nuts, one at each end of beam extrusion, and discard.
3. Remove both foot attachment bolts and both foot assemblies and set aside for later use.
4. Discard old beam extrusion.
5. Place new beam extrusion on secure work platform.
6. Reinstall each foot assembly and attachment bolts and secure with new attachment nuts. Ensure replacement beam extrusion is positioned so that labels are oriented properly so they face the back of the trailer and are right side up when the beam is installed.
7. Tighten lock nuts to fully engage nylok element and expose a minimum of one full thread on the bolt. Do not over-tighten, as deformation of beam side can cause restrictions in the motion of the foot assembly in the beam.
8. Install beam and reinstall beam stops per ***Beam Assembly Installation*** instructions above.

Beam Extrusions Replacement - Without Removing the Beams

1. Ensure both foot assemblies are functional and not worn or damaged.
2. After bringing the beam assembly down to working height, remove both bolts and nuts that attach the foot assembly to the beam extrusion.
3. Raise one end of the beam up to allow the extrusion end to disengage from the foot assembly steel tube. Slide the beam extrusion off both foot assemblies.
4. Install the new beam extrusion onto the foot assemblies and reinstall the nuts and bolts.

Repair and Parts Manual

5. Tighten lock nuts to fully engage Nylok element and expose a minimum of one full thread on the bolt. Do not over-tighten, as deformation of beam side can cause restrictions in the motion of the foot assembly in the beam.

Beam Foot Assembly Replacement

1. Remove beam stops and beams per ***Beam Assembly Removal*** instructions on page 15, and place beam on secure work platform.
2. Remove beam foot assembly attachment nut from affected end, and discard.
3. Remove beam foot assembly attachment bolt and set aside for later use.
4. Remove and discard old damaged beam foot assembly.
5. Install new beam foot assembly and lock nut, reusing the attachment bolt. Ensure new beam foot assembly is oriented the same as the foot assembly on opposite end of the beam.
6. Tighten lock nuts to fully engage Nylok element and expose a minimum of one full thread on the bolt. Do not over-tighten, as deformation of beam side can cause restrictions in the motion of the foot assembly in the beam.
7. Install beam and reinstall beam stops per ***Beam Assembly Installation*** instructions on page 15.

Beam Foot Replacement

1. Remove beam stops and beams per ***Beam Assembly Removal*** instructions on page 15, and place beam on secure work platform.
2. Remove beam foot attachment nut and bolt from affected end and discard.
3. Remove and discard old damaged beam foot.
4. Install new beam foot and lock nut and bolt. Ensure new beam foot is oriented the same as the beam foot on the opposite end of the beam.
5. Tighten lock nuts to fully engage nylok element and expose a minimum of one full thread on the bolt. Do not over-tighten, as deformation will cause restrictions in the motion of the foot in the beam. Make sure the beam foot pivots easily in the steel tube of the beam foot assembly.
6. Install beam and reinstall beam stops per ***Beam Assembly Installation*** instructions on page 15.

Repair and Parts Manual

LAD II Track

TRACK TOP

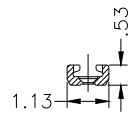
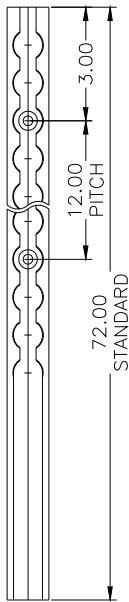

Narrow Single Track
49562-17-72.00

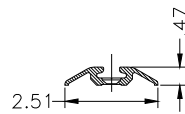
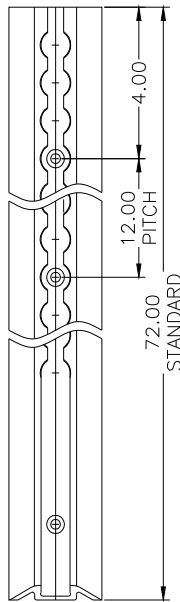

Standard Single Track
w/Bevel
50192-14-72.00

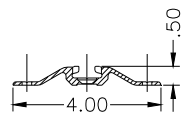
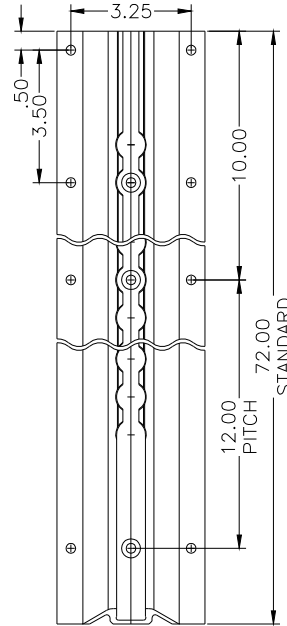

Flanged Single Track
w/Bevel
50058-18-72.00

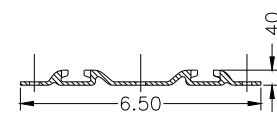
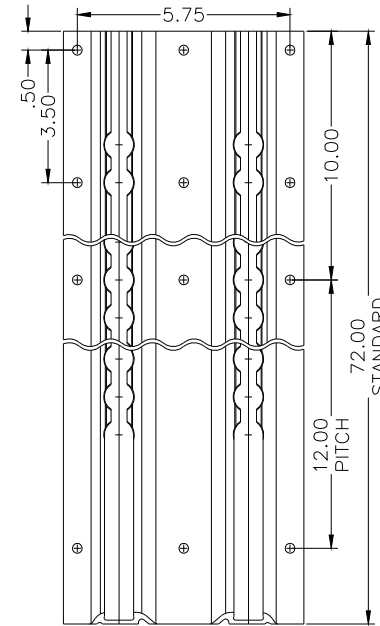

Flanged Double Track
w/Bevel
50072-14-72.00

TRACK BOTTOM

Repair and Parts Manual

LAD II Track Inspections

Regularly inspect track and track mounting components for damage and excessive wear.

Replace or repair missing or damaged components as necessary to ensure proper functioning.

1. Ensure tracks are free of any substance that will cause the build-up of foreign material that will hamper operation.
2. Inspect track for damage. (See Appendix B)
3. Ensure all track attachment hardware is secure.
4. Ensure all beam stops are in place and secure.

Track Replacement Criteria

Tracks must be replaced if any of the following conditions are found;

1. Deformations – twists, bends or curves in track. Use inspection tool 50064-10 to insure proper inside track clearance for proper system function.
2. Wear that reduces the distance between holes below 0.29", illustrated below.
3. Holes or cracks
4. Cracked or missing track flange teeth
5. Any other damage where the system integrity is in question

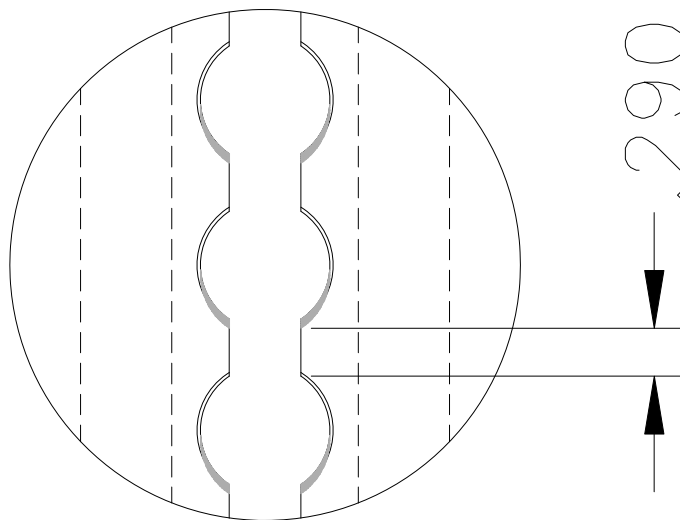

Repair and Parts Manual

Track Removal

1. Remove beam stops and beams per **Beam Assembly Removal** instructions on page 15, to allow removal of affected track. Set them aside for later reuse.
2. Remove and discard all attachment rivets from effected track.
3. If “Filler Strips” are installed, set them aside for reinstallation with new track.
4. Discard damaged track.

Recommended Track Attachment Fasteners

Installer provides fasteners.

Sheet & Post Type Trailer Wall Construction

Fastener Type	Commercial Fasteners (Huck)*	
100° Flush Head	MGL-100-R8-XX**	MBV-R8-XX**
Protruding Head	MGLP-R8-XX**	MBP-R8-XX**

*MGL and MGLP are preferred. MBV and MBP are optional when space is limited between post and outside wall.

**XX = Grip Length. Overall length of rivet is dictated by grip length. Grip length is determined by the distance between the inside track surface to outside surface of post or structural member. This is the thickness of the stack of material being secured by the rivet.

Plate Type Trailer Wall Construction

- Structural Buck Rivets must be used for attaching track. Length of rivets needs to be determined by the required grip length. Grip length is the distance from inside track surface to outside surface of post or structural member.
- Flanged track must be used in plate trailer applications with all of the attachment rivets on the flanges.

Replacement Track Installation

1. Align holes in matching track with holes in trailer support post or plate wall.
2. Install track using recommended rivets. Ensure all track holes are filled.

Note: For plate trailers install structural buck rivets in track flanges only.

3. If a rivet hole gets too large from re-drilling (0.280” MAX) a new hole may be drilled through the track flange and trailer post offset no less than 0.5” above or below the defective hole.
4. To ensure all flush head rivets do not impede beam foot travel use LAD II Track Inspection Tool, PN# 50064-10.

Note: For plate trailers install structural buck rivets in track flanges only.

5. Reinstall beam and reinstall beam stops per **Beam Assembly Installation** instructions on page 15.

Repair and Parts Manual

LAD II Beam Stop



Beam Stop Installation

1. Place Beam Stop, PN#49384-12, into track, above the installation/removal slot as shown below. Using a 5/32" Allen Wrench, seat screw and tighten an additional quarter turn.
Torque beam stop screws to a maximum of 20-25 in-lbs.

DO NOT OVERTORQUE THE BEAM STOP SCREWS.

WARNING: DO NOT OPERATE LAD II SYSTEM UNTIL ALL BEAM STOPS ARE IN PLACE.

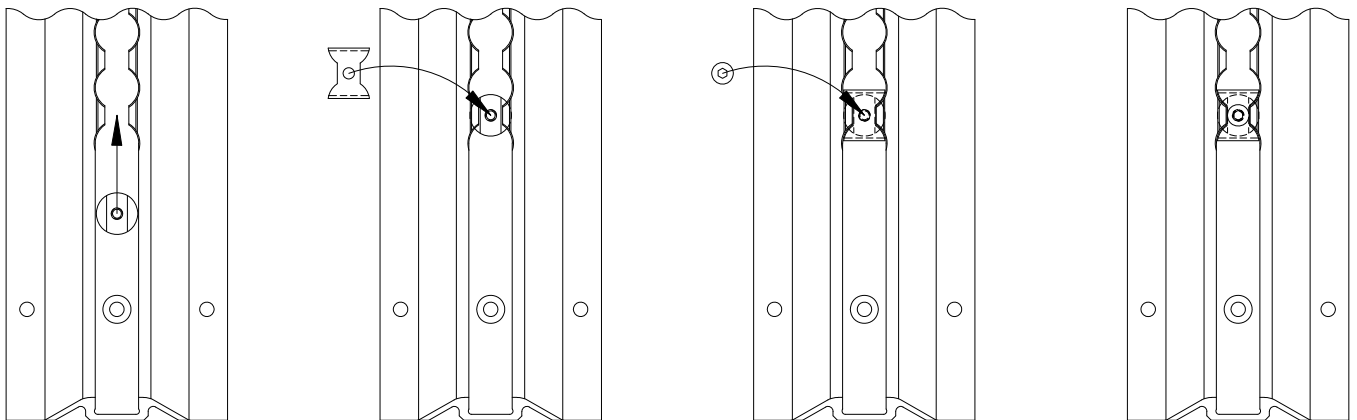

Repair and Parts Manual

LAD II Door Track Guard (For Roll-Up Door Trailers Only)

The Door Guard, PN#50030-12, is installed just below the door track at the top of the LAD Track to prevent LAD Beams from impacting the door when pushed to the storage position and prevent the door from impacting the LAD Beams during door operation.

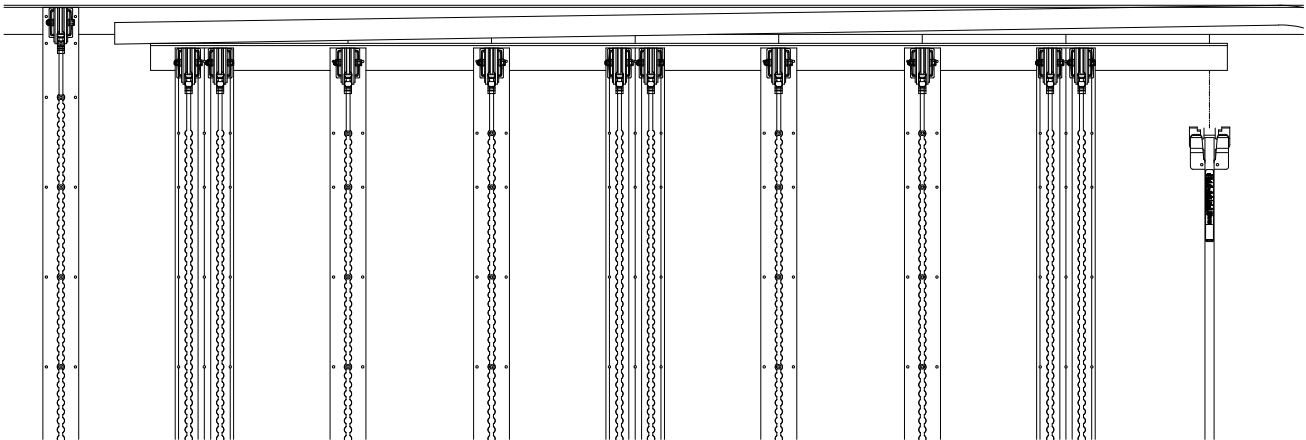

Door Track Guard Removal

1. Remove beam stops and beams per **Beam Assembly Removal** instructions on page 15, to allow removal of affected door track guard. Set them aside for later reuse.
2. Remove and discard all attachment rivets from effected door track guard.
3. For Doubler Installations, removal of filler strips and rivets from upper portions of track may be necessary to remove door track guard.
4. Slide door track guard forward over track forward of door area.
5. Discard old damaged door track guard.

Door Track Guard Installation

1. Slide new door track guard into place on top of door area track from the forward end of the door area.
2. Ensure the door track end bolt is exposed and drill through the holes of the track and the door guard, and install recommended rivets.
3. Install recommended rivets in all remaining track holes. Ensure all track holes are filled.

Note: For plate trailers install structural buck rivets in track flanges only.

4. If a rivet hole gets too large from re-drilling (0.280" MAX) a new hole may be drilled through the door track guard and trailer post offset not less than 0.5" above or below the defective hole.

Repair and Parts Manual

5. Reinstall beam and reinstall beam stops per *Beam Assembly Installation* instructions on page 15.

LAD II Adjustment Tool

Adjustment Tool, PN#49445-12, is used to operate the beam up and down the track and release it from its storage location.

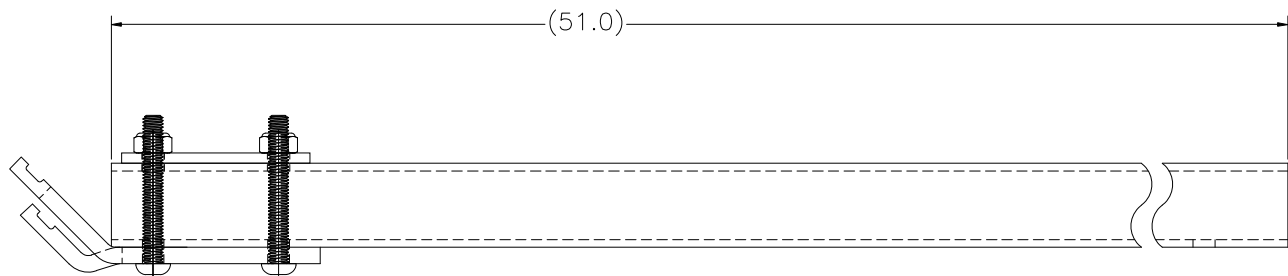
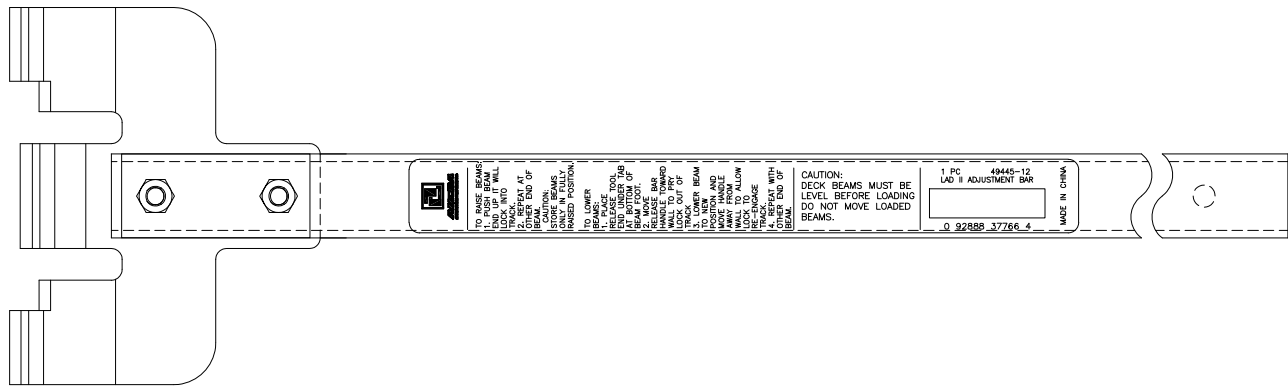

Adjustment Tool Repair – Loose Rivets

Remove and replace loose rivets with ¼-20 UNC x 1.5/8” long hex head bolts and lock nuts. Drill through the aluminum handle using a #F drill bit (.257 dia.). Use heavy flat washers under the nuts.

Repair and Parts Manual

LAD II Adjustment Tool Holder and Wall Placard

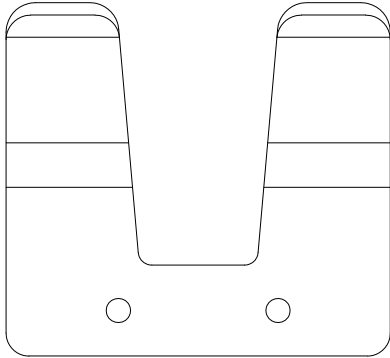

Adjustment Tool Holder Replacement

PN#50055-10

1. Remove damaged holder, if present.
2. Install release beam holder on the inside wall, on the right rear side of the trailer. Locate the center of the holder in line with the center of the last post approx. 15" down from the top rail, as illustrated right. Drill and install with two protruding head rivets.

Wall Placard Replacement

PN#49438-13

1. Remove any remaining placard.
2. Make sure the area has been properly cleaned and dry before applying the decal.
3. Install adhesive backed information placard on the right rear wall centered between the last post and the front edge of the door track. Locate the bottom edge approx. 58" from the floor.

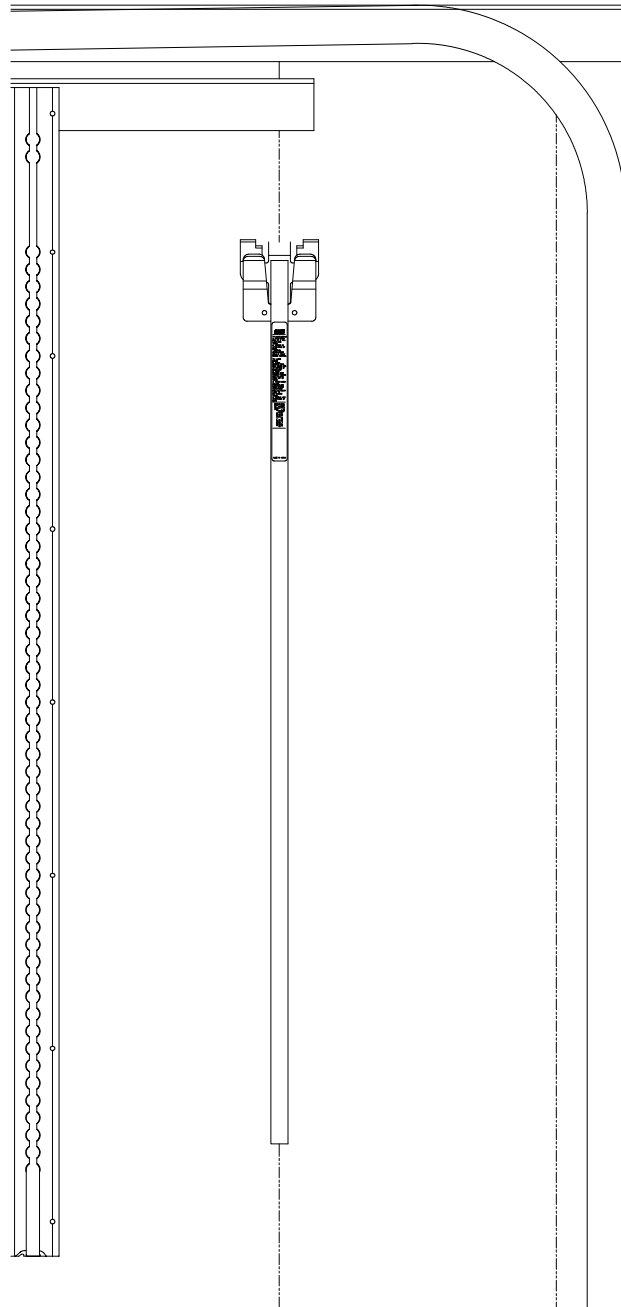

Repair and Parts Manual

Repair of Loose or Missing Track Attachment Rivets

1. Replace any loose or missing rivets in holes that are not elongated with recommended rivets.
2. In the case where the hole is elongated, for flanged track, door track guard or doubler, it may be necessary to drill a new hole adjacent to the existing hole, offset not less than 0.5” above or below, and install a recommended rivet.
3. In the case where the elongated hole is in double track, it may be necessary to drill and countersink a new hole in the adjacent track hole, and install a recommended rivet.

Logistic Strap Replacement Criteria

Logistic Straps must be removed from service if any of the following conditions exist;

1. Excessive abrasive wear
2. Chemical burns
3. Tears, holes, cuts or snags in webbing
4. Broken or missing hardware
5. Melting or charring of webbing
6. Broken, worn or missing stitching in sew patterns

System Lubrication

1. Track does not require lubrication.
2. The LAD II System has been designed for a minimum service life of five years, under normal conditions. To significantly extend expected track service life, the use of the penetrating lubricant “Penetro90” can be used. This should only be used in the slot portion of the track, following the manufacturer’s instructions.
3. Moving parts of end fittings do **not** require lubrication. End fittings should **not** be lubricated as it is unnecessary and some types of lubricants can gum up the mechanism and cause additional wear.

Repair and Parts Manual

Appendix A, Replacement Beams & Beam Parts Weights

Part Number	Nomenclature	Weights
49414-14	Standard Beam	16.56
49414-14-RT	Beam H.D., Includes Decals	10.02
49414-15	Standard Beam	18.15
49414-15-RT	Beam H.D., Includes Decals	10.78
49414-17	Standard Beam w/Extended Foot	19.35
49414-17-RT	Beam H.D., Includes Decals	10.78
49414-19	HD Beam Assembly	19.75
49414-19-RT	Beam H.D., Includes Decals	13.19
49414-23	HD Beam Assembly w/Extended Foot	21.75
49414-23-RT	Beam H.D., Includes Decals	13.19
49414-24	HD Beam Assembly	19.75
49414-24-RT	Beam H.D., Includes Decals	13.19
49414-25	HD Beam Assembly	19.37
49414-25-RT	Beam H.D., Includes Decals	12.81
49414-54	Beam Foot	4.16
49811-20L	LAD II Foot Assembly	3.15
49811-21L	Beam Foot	0.60
50080-11	Wide Flange Beam Assembly	24.80
50080-11-RT	Wide Flange Beam, Includes Decals	18.33
50187-30	LAD II Foot Assembly	2.98
50187-31	Beam Foot	0.43
50312-10	Reinforced Wide Top Beam Assy	26.70
50312-10-RT	Reinforced Wide Top Beam, Includes Decals	20.40
50194-100	Low Profile Fastener Kit (10ea)	1.00

Repair and Parts Manual

Appendix B, Replacement Track & Parts Weights

Part Number	Nomenclature	Weights (lbs)
49562-17-72.00	Narrow Single Track	2.70
50192-14-72.00	Standard Single Track w/Bottom Bevel	3.30
50058-18-72.00	Flanged Single Track w/Bottom Bevel	4.20
50072-14-72.00	Flanged Double Track w/Bottom Bevel	6.78
40340-27	Single Stud Track Fitting	0.09
47556-11	Double Stud Fitting	0.35
49384-12	Track Stop	0.04
49438-12	LAD II Instruction Placard	0.01
49445-12	Adjustment Tool	2.45
49446-10	LAD II Accessory Kit	2.45
50030-12	Door Guard	9.80
50031-10	179.75" Doubler	13.48
50031-11	130" Doubler	9.75
50032-14	28.88" Filler Strip	0.92
50032-15	26.00" Filler Strip	0.83
50055-10	LAD Adjustment Tool Holder	0.25
50105-10	Poly Deck Board	23.00

Repair and Parts Manual

Appendix C, Examples of Damaged Beams and Track

Typical Examples of Damaged Beams



Bent Beam Extrusion

Repair and Parts Manual

Typical Examples of Damaged Beams, cont.



Beam Extrusion Sidewall Buckled

Repair and Parts Manual

Typical Examples of Damaged Beams, cont.



Excessive Wear on LAD II Beam Foot Lock Key

Repair and Parts Manual

Typical Examples of Damaged Beams, cont.



Excessive Wear on LAD II Beam Foot Lock Key

Repair and Parts Manual

Typical Examples of Damaged Track



Damaged Track- Missing track lug



Damaged Track – Surface wear

Repair and Parts Manual

Typical Examples of Damaged Track, cont.

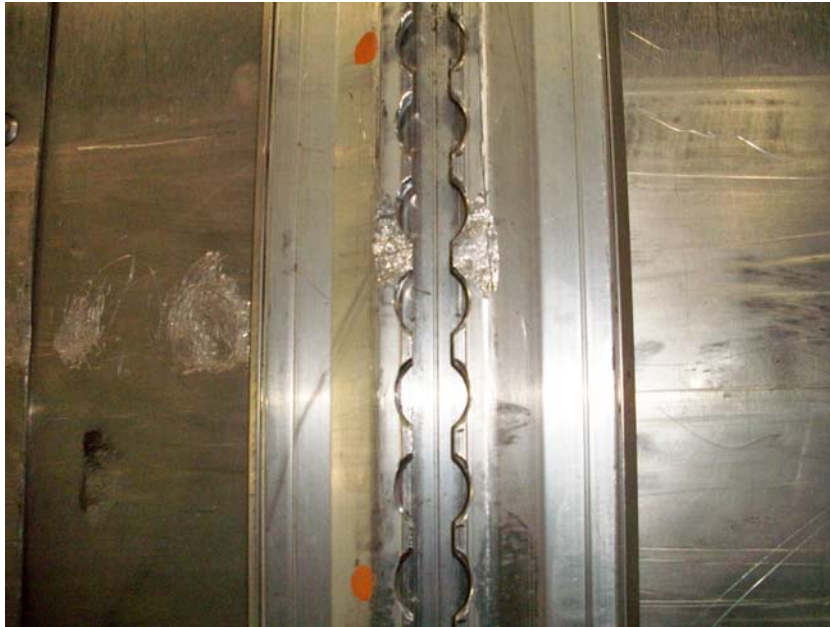

Damaged Track – Surface wear

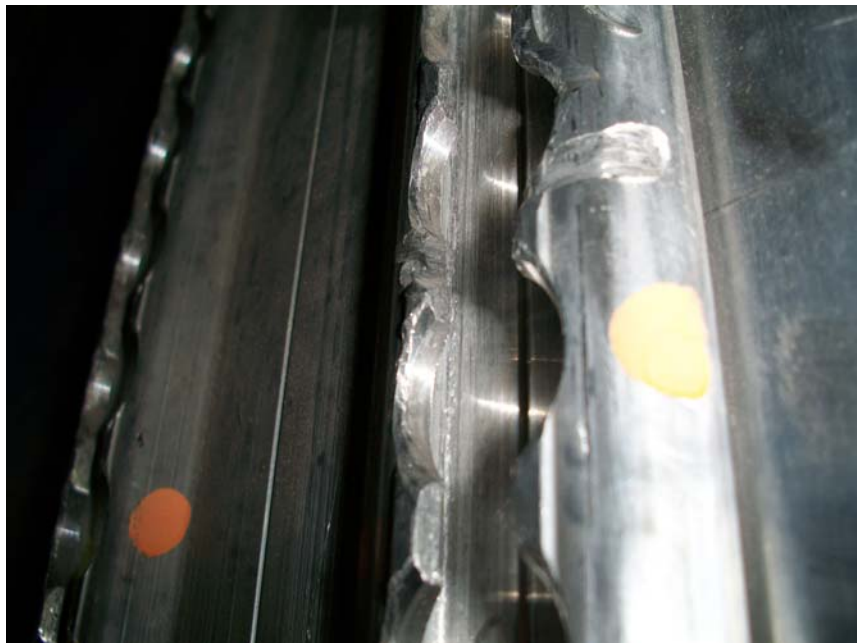

Damaged Track – Damaged lug