

# PAN FITTING with Collar Trim Plate

P/N 45545-10 without trim collar  
P/N 45545-11 with trim collar

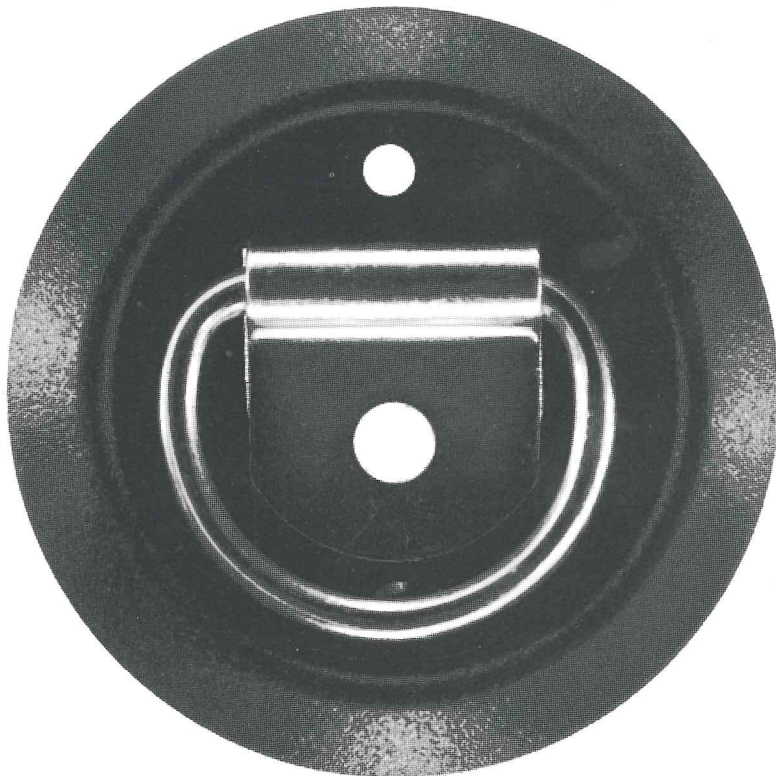

shown actual size

**Designed for Low Profile  
mounting in trucks  
and cargo containers.**

**NEW! IMPROVED!  
with many new  
exclusive features.**

**Fast, easy,  
“one piece” installation**

**Load Capacity, 1,200 lbs.**

The new design Pan Fitting features an interlocking recess which provides self centering of the ring in the trim collar and the special anti-rotation feature maintains the Pan Fitting in position for easy mounting. Durable and sturdy, trim collar manufactured of high quality corrosion resistant material, & steel components are zinc plated for corrosion resistance.

# PAN FITTING with Collar/Trim Plate

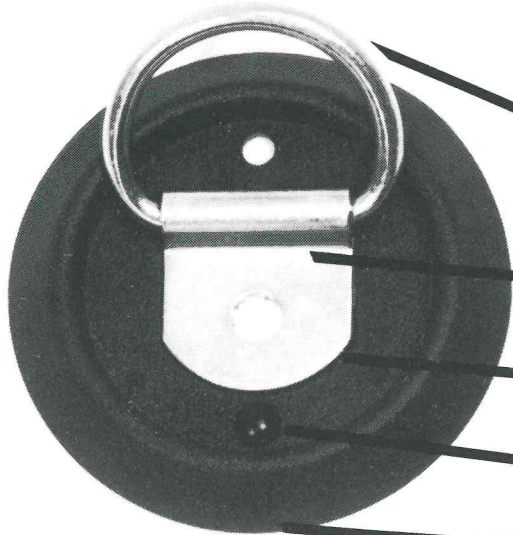

## FEATURES:

**STEEL RING** 1/4" diameter, recessed into collar trim plate corrosion resistant zinc plated and chromate coated.

**STEEL STRAP** is zinc plated and chromate coated for ultimate resistance against rust and corrosion.

**INTERLOCKING RECESS.** Provides self-centering of the strap and ring during installation.

**RAISED BUTTON** on the trim plate, keeps the ring free for easy lift access.

**TRIM PLATE COLLAR.** Sturdy high density polyethylene with a textured grain finish.

**ANTI-ROTATION PROJECTIONS** assists in reducing pan fitting rotation during mounting operation.

### INSTALLATION:

For low profile mounting without cutting into plywood. Ready to install. Tape on the back of the assembly holds the entire unit in place for easy installation.

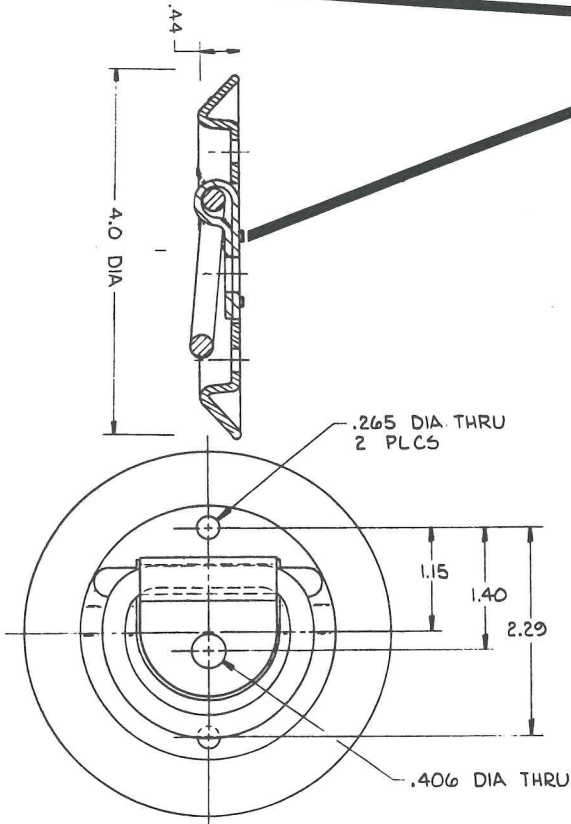

### SPECIFICATIONS:

Overall Diameter 4"

Assembly Height .44"

Positioning Hole Diameter .265"

Center Hole Diameter .406"

Load Capacity 4,200 lbs. *1600 lbs*

designed to use with Camcar fasteners in FRP application.



# ANCRA CORPORATION

2233 EAST GRAND AVENUE  
EL SEGUNDO, CALIFORNIA 90245  
TELEPHONE (213) 322-7365 TWX (910) 348-7118

### MANUFACTURING/SALES FACILITIES

**ANCRA CORPORATION MIDWEST**  
1115 WEST NATIONAL AVENUE  
ADDISON, ILLINOIS 60101-3177  
TELEPHONE: (312) 628-1200  
TELEX: 3724782

**ANCRA EAST, INC.**  
248 BRANFORD ROAD  
NORTH BRANFORD, CONNECTICUT 06471-1303  
TELEPHONE: (203) 488-0602  
TELEX: 3722029

**ANCRA NORTH, INC.**  
4420 RUSSELL ROAD  
LYNNWOOD, WASHINGTON 98037-5017  
TELEPHONE: (206) 353-7211  
TELEX: 3794031

**ANCRA INTERNATIONAL LTD.**  
MARLING MILLS  
NELSON STREET  
LEEK, STAFFORDSHIRE, ENGLAND  
(0538) 384103 TELEX 36133

**FREIGHT LOCK PTY LTD.**  
4 EDINBURG ST.  
S. OAKLEIGH 3167  
AUSTRALIA  
TELEPHONE: (3) 544-6866  
TELEX: AA30333

**ANCRA CANADA LTD.**  
335 NUGGET AVENUE  
UNIT NO. 4  
SCARBOROUGH, ONTARIO M1S 4J3  
CANADA  
TELEPHONE: (416) 299-3200  
FAX: (416) 299-4274

**ANCRA JUNGFALK GmbH**  
D-7707 ENGEN 1  
RICHARD-STOCKER-STR 19  
WEST GERMANY  
TELEPHONE: (7733) 6075  
TELEX: (841) 07 93 876  
FAX: (7733) 5776

**ANCRA SOUTH, INC.**  
1559 TAYLOR AVENUE  
EAST POINT, GEORGIA 30344-4242  
TELEPHONE: (404) 768-2554  
TELEX: 3729952

**ANCRA SOUTHWEST, INC.**  
920 AVENUE N  
GRAND PRAIRIE, TEXAS 75050-1918  
TELEPHONE: (214) 988-3384  
TELEX: 3787618

**ANCRA CORPORATION**  
BUILDING 633  
OAKLAND INTL AIRPORT  
OAKLAND, CALIFORNIA 94614  
TELEPHONE: (415) 568-8308

**BAYBARZ**  
885 EAST LODI AVENUE  
LODI, CALIFORNIA 95240  
TELEPHONE (209) 368-0631

**ANCRA INTERNATIONAL B.V.**  
INDUSTRIEWEG 13  
5281 RW BOXTEL, HOLLAND  
TELEPHONE: 4116-78675  
TELEX: NL 50593  
FAX: 4116-82195

**ANCRA INTERNATIONAL S.A.**  
CENTRE INDUSTRIEL  
LOCATIF RHONE ALPE  
9, RUE DE COPENHAUG  
38290-ST. QUENTIN FALLAVIER, FRANCE  
TELEX: 370350  
TELEPHONE: (74) 944777

**ANCRA CORPORATION**  
29535 SUTTON DRIVE  
NORTH OLMSTED, OHIO 44070  
TELEPHONE: (216) 442-1298